

**LONCIN**

**POWERING  
THE FUTURE**



**BARRUS**



# Inverter Generators

## MULTIPLE FREQUENCY SPWM INVERTER TECHNOLOGY

The exclusively patented Multiple Frequency SPWM Inverter Technology offers a higher quality power output compared with ordinary frequency conversion technology. Its power quality conforms to international communication power supply secondary standard, and is superior to the national grid. It can be used as an outdoor portable power source and emergency power source for household electronic products.

## TWO CHAMBER CRANK CASE BREATHER

The unique two chamber crank case breather plays a very important role on the LC148F engine. A condensing oil and gas separation chamber is added in the circulation path of the engine oil and exhaust gas, where exhaust gas from crankcase experience two stage oil - gas separation. It greatly improves separation efficiency, reduces oil consumption and extends the service life of the engine. The oil consumption could be only 1.1g/kilowatt-hour.

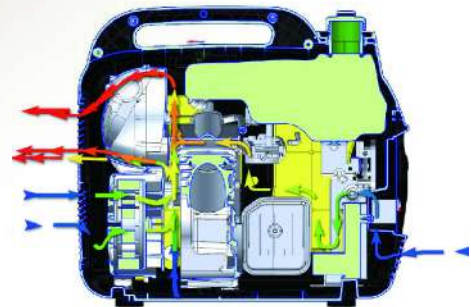

## 3-WAY AIR COOLING CIRCULATION TECHNOLOGY

3-way air cooling circulation technology can extract cooling air from three different air inlets simultaneously, which complete the heat dissipation and cooling for several parts like inverter, engine, alternator etc. The three cooling airflow work separately and do not interfere with each other. The independent patent technology of a two-way air inlet impeller use the theory of radial flow impeller, which single impeller has the two-way air inlet function. This is to achieve the effect of cooling the alternator and hotspot all together, and the temperature rise for alternator is below 54K, while for hotspot is below 75°C, which guarantee the reliability of the inverter generator.

## LOW-NOISE, LIGHTWEIGHT, PORTABLE AND ENVIRONMENTALLY FRIENDLY

ESC Intelligent speed control technology can adjust the engine speed according to the output load which saves 11% fuel consumption and reduces noise operation by 15% to 52dBA from a distance of 7 metres. The inverter generator LC2000i conforms to the latest European Emission Regulation Standards.





# Inverter Generators

## PROFESSIONAL INVERTER GENERATORS

This Loncin Inverter Generator is extremely quiet and reliable, and can be used to power anything from electronics to power tools. The parallel-ready design allows connecting two units together via cables. With less than 1.5% total harmonic distortion, this easily portable generator safely runs sensitive electronics with no interruptions or disturbances. 100% copper-wound heads allow operation at full load continuously for weeks without overheating – lasting longer, running cooler and without corroding compared to aluminium heads.

## PORTABLE POWER AND CONVENIENCE

The lightweight, easily portable Loncin Inverter Generator is rugged and ready to go wherever and whenever you need a reliable power source. You can take it camping, to a building site or and outdoor/sporting event. Whether you need convenience power or emergency power, the Loncin Inverter Generator is up to the task. With up to 2000 surge watts, there is enough power to operate today's essential electronics and small power tools.

## LC2000I-S (110V5)

Electrical output: 1.8kW max, 1.6kW rated

## LC2000I5 (230V)

Electrical output: 1.8kW max, 1.6kW rated

## LC3000I5 (230V)

Electrical output: 2.5kW max, 2.3 kW rated

## CLEAN POWER, FUEL-EFFICIENT AND QUIET

With less than 1.5% total harmonic distortion, the Loncin Inverter Generator provides power as safe, clean and reliable power you can get from your home's electrical outlets. You can trust it to safely run all your sensitive electronics with no interruptions or disturbances.

## ENVIRONMENTALLY-FRIENDLY

The Loncin Inverter Generator uses advanced Engine Smart Control and variable engine speed to use only the required engine power, helping reduce fuel consumption. It is also equipped with an "LC-POWER" low carbon powered engine that meets USA epa3 emission standard.

## SMALL SIZED, LIGHTWEIGHT AND MORE QUIET

The Loncin Inverter Generator is small in size and light weight. The noise level is 52dB at a distance of 7 metres –30%-50% lower than that of ordinary generator sets- which ensures quiet operation in an office or for outdoor leisure.



	<b>LC2000I-S (110V5)</b> Electrical output: 1.8kW max, 1.6kW rated	<b>LC2000I5 (230V)</b> Electrical output: 1.8kW max, 1.6kW rated	<b>LC3000I5 (230V)</b> Electrical output: 2.5kW max, 2.3kW rated
Engine Type	Single Cylinder, 4 stroke, forced cooling OHV		
Rated Output hp / (kW)	2.1 / (1.6)		3.0 / (2.3)
Bore x Stroke (mm)	48.6 x 43		65 x 45
Displacement (cc)	79		149
Compression Ratio	9 : 1		
Fuel Capacity (L)	4.2		4.5
Fuel Consumption (g/kW h)	≤ 395		
Running Time (h)	7		
Rated Frequency (Hz)	50		
Rated Voltage (V)	110	230	
Voltage Regulator System	FM-SPWM III		
Rated Output (kW)	1.6		2.3
Max Output (kW)	1.8		2.5
Power Factor	1.0		
DC Voltage (V)	12		
DC Current (A)	8.3		8.0
Starting System	Recoil		
Ignition System	C.D.I		
Noise (≤ 7m)	61dBA		
Dimensions (L x W x H mm)	499 x 285 x 455		
Net Weight (kg)	21		26.5
Oil Capacity (L)	0.35		

"S" inverters can be synchronised with additional "S" inverters



# Inverter Generators

## LC3500I5

Electrical output: 3.3kW max, 3kW rated

## LC7500I5

Electrical output: 7.5kW max, 6.5kW rated

### PROFESSIONAL INVERTER GENERATORS

This Loncin Inverter Generator is extremely quiet and reliable, and can be used to power anything from electronics to power tools. The parallel-ready design allows connecting two units together via cables. With less than 1.5% total harmonic distortion, this easily portable generator safely runs sensitive electronics with no interruptions or disturbances. 100% copper-wound heads allow operation at full load continuously for weeks without overheating – lasting longer, running cooler and without corroding compared to aluminium heads.

### PORTABLE POWER AND CONVENIENCE

The lightweight, easily portable Loncin Inverter Generator is rugged and ready to go wherever and whenever you need a reliable power source. You can take it camping, to a building site or and outdoor/sporting event. Whether you need convenience power or emergency power, the Loncin Inverter Generator is up to the task. With up to 2000 surge watts, there is enough power to operate today's essential electronics and small power tools.

### CLEAN POWER, FUEL-EFFICIENT AND QUIET

With less than 1.5% total harmonic distortion, the Loncin Inverter Generator provides power as safe, clean and reliable power you can get from your home's electrical outlets. You can trust it to safely run all your sensitive electronics with no interruptions or disturbances.

### ENVIRONMENTALLY-FRIENDLY

The Loncin Inverter Generator uses advanced Engine Smart Control and variable engine speed to use only the required engine power, helping reduce fuel consumption. It is also equipped with an "LC-POWER" low carbon powered engine that meets USA epa3 emission standard.

### ELECTRIC START

The Loncin Inverter Generator can be started quickly and easily with the push of a button.



	<b>LC350015</b> Electrical output: 3.3kW max, 3kW rated	<b>LC750015</b> Electrical output: 7.5kW max, 6.5kW rated
Engine Type	Single Cylinder, 4 stroke, forced cooling OHV	
Rated Output hp / (kW)	4.0 / (3.0)	8.0 / (6.0)
Bore x Stroke (mm)	70 x 55	90 x 66
Displacement (cc)	212	420
Compression Ratio	8.5 : 1	
Fuel Capacity (L)	10	25
Fuel Consumption (g/kW h)	≤ 395	≤ 4.3 litres/h
Running Time (h)	11	
Rated Frequency (Hz)	50	50 / 60
Rated Voltage (V)	230	230
Voltage Regulator System	FM-SPWM III	
Rated Output (kW)	3.0	6.5
Max Output (kW)	3.3	7.5
Power Factor	1.0	
DC Voltage (V)	12	
DC Current (A)	8	
Starting System	Recoil / electric	Recoil / electric
Ignition System	C.D.I	
Noise (≤ 7m)	65dBA	58dBA
Dimensions (L x W x H mm)	578 x 440 x 510	920 x 765 x 773
Net Weight (kg)	45	130
Oil Capacity (L)	0.6	1.35



# Open Frame AVR Controlled Generators

## AUTOMATIC VOLTAGE REGULATOR

The Automatic Voltage Regulator prevents voltage surges to protect your electrical equipment.

## DUAL VOLTAGE

The Loncin open frame generators have 110v or 230v outputs.

## HEAVY DUTY FRAME

The Loncin open frame generators have a heavy duty frame making them portable and robust. The LC6000D-A and LC8000D-A have 2 wheels and fold out handles.

## HIGH CAPACITY FUEL TANKS

The Loncin open frame generators have high capacity fuel tanks for long running. The LC2500-AS and LC3500-AS have 18 litre fuel tanks and the LC6000D-A and LC8000D-A have 25 litre fuel tanks.

## LC2500-AS5

Electrical output : 2.2kW max, 2kW rated

## LC3500-AS5

Electrical output : 3.1kW max, 2.8kW rated

## LC6500D-AS5

Electrical output : 5.5kW max, 5kW rated

## LC8000D-AS5

Electrical output : 6.5kW max, 6kW rated



	<b>LC2500-AS5</b> Electrical output: 2.2kW max, 2kW rated	<b>LC3500-AS5</b> Electrical output: 3.1kW max, 2.8kW rated	<b>LC6500D-AS5</b> Electrical output: 5.5kW max, 5kW rated	<b>LC8000D-AS5</b> Electrical output: 6.5kW max, 6kW rated
Engine Model	G200F/G200FD	G210FA/G210FAD	G390F/G390FD	G420F/G420FD
Engine Type	Single cylinder, 4 stroke, OHV 25° inclined, forced air cooling			
Net Power hp / (kW)	5.5 / (4.1)	5.9 / (4.4)	11 / (8.2)	12 / (9.0)
Bore x Stroke (mm)	68 x 54	70 x 55	88 x 64	90 x 66
Displacement (cc)	196	212	389	420
Compression Ratio	8.5 : 1	8.2 : 1	8.0 : 1	8.3 : 1
Oil Capacity (L)	0.6		1.1	
Fuel Tank Capacity (L)	18		25	
Fuel Consumption (g/kw h)	≤ 395		≤ 374	
Approx Running Time (h)	Dependant on load		9	8
Rated Frequency (Hz)	50			
Rated Voltage (V)	110 / 230			
Voltage Regulator System	Automatic voltage regulation			
Sockets	2 x 16 amp		3 x 32 amp	
Rated Output (kW)	2	2.8	5.0	6.0
Max Output (kW)	2.2	3.1	5.5	7.5
Power Factor	1.0			
DC Charging Voltage (V)	12 (DC)			
DC Charging Current (A)	8.3 (DC)			
Starting System	Recoil		Recoil / Electric start	
Ignition System	Transistorized magneto			
Noise (≤ 7m)	76dBA			
Dimensions (L x W x H mm)	590 x 430 x 467		681 x 546 x 550	681 x 546 x 550
Net Weight (kg)	40	47	79	87



# Typical Application Power Rating

## 1000 Watts / 1.25kVA = 1.0k.W

ELECTRICAL EQUIPMENT	APPROX WATTAGE
Air Con 1hp	2500
Angle Grinder 125 mm	1100
Angle Grinder 230 mm	2200
Belt Sander	1100
Cement Mixer (Small)	1500
Central Heating Pump	800
Chainsaw	1600
Concrete Poker	2500
Cooker	12000 (minimum)
Computer and VDU	700
Coffee Machine	1300
Dehumidifier	3000
Deep Freeze	1500
Demolition Breaker	2400
Dishwasher	2000 - 3000

ELECTRICAL EQUIPMENT	APPROX WATTAGE
Fan Heater (2 bar)	2000
Fax Machine	600
Flood Light TH	500
Flood Light MH	1000
Fluorescent Tube	60
Floor Sander (200mm)	2000
Food Mixer	500
Fridge	700 - 1000
Hair Dryer	1500 - 2300
Hair Straighteners	150
Hammer Drill	1000
Hedge Trimmer	600
Hi-Fi	300
Hot Air Gun	3000

This is an approximate guide only. Please consult the equipment manufacturer for precise wattage.  
If in doubt, select next largest generator.



ELECTRICAL EQUIPMENT	APPROX WATTAGE
Iron	1000
Iron (Steam)	2200
Jigsaw	600
Kettle	2500 - 3000
Lawnmower	600 - 1200
Lawn Raker	500
Light Bulb (Domestic std)	25 - 100
Microwave 900W	1500
Orbital Sander	500
Planer	1000
Power Drill	500 - 900
Power Float	1500
Photocopier	1500
Pressure Washer	3000 - 6000
Printer	400

ELECTRICAL EQUIPMENT	APPROX WATTAGE
Radiator (Oil Filled)	1000 - 2000
Router	1600 - 1900
Saw (Chain)	1500
Saw 250mm (Masonry)	4000
Saw (Mitre)	1600
SAT / Cable TV Receiver	25
Strimmer	500
Television	200
Toaster	1050 - 1500
Treadmill (Domestic)	2300
Tumble Dryer	2500
Vacuum Cleaner	1000 - 1300
Washing Machine	4000
Water Heater	3000

This is an approximate guide only. Please consult the equipment manufacturer for precise wattage. If in doubt, select next largest generator.



# Open Frame Pumps

## Water & Semi Trash

Water pumps are a useful tool for a variety of residential, light commercial and agricultural tasks. A water pump is ideal for:

- Draining water from a basement
- Draining and filling your swimming pool, pond or hot tub
- Draining shallow flooded areas
- Irrigation purposes for agricultural or lawn sprinkling
- Distributing fertilizers and pesticides
- Various other tasks including construction purposes

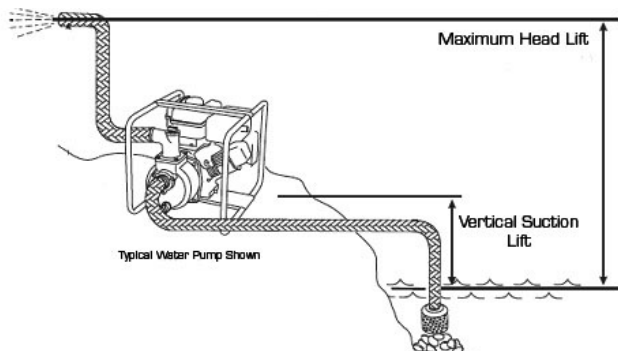

### HOW DO I CHOOSE THE RIGHT PUMPS FOR MY NEEDS?

When shopping for a water pump there are various items to consider. All water pumps are measured in discharge capacity (GPM), vertical suction lift, and maximum head lift.

Discharge Capacity is the rate of speed that water flows from the source to the discharge point, measured in litres per minute. It provides the power to move water quickly.

Vertical Suction Lift is the vertical distance from the water source to the pump. This is important for draining a basement or deep pond.

Maximum Head Lift is the total height from the source of the water to the destination or drainage point. This provides the power to move water over a distance.



**LC25ZB21-1.7Q5 GENERAL PUMP**

- 1" discharge diameter
- 21 metre lift
- 8,000 litre delivery volume
- 13 kg net weight



**LC50ZB30-4.5Q5 GENERAL PUMP**

- 2" discharge diameter
- 23 metre lift
- 30,000 litre delivery volume
- 23 kg net weight



**LC80ZB35-4.5Q5 GENERAL PUMP**

- 3" discharge diameter
- 35 metre lift
- 60,000 litre delivery volume
- 28 kg net weight



**LC50ZB60-4.5Q5 HIGH LIFT PUMP**

- 2" discharge diameter
- 60 metre lift
- 30,000 litre delivery volume
- 30.5 kg net weight



**LC80WB30-4.5Q5 SEMI TRASH PUMP**

- 3" discharge diameter
- 30 metre lift
- 45,000 litre delivery volume
- 39 kg net weight



# Open Frame Pumps Flow Chart & Specifications

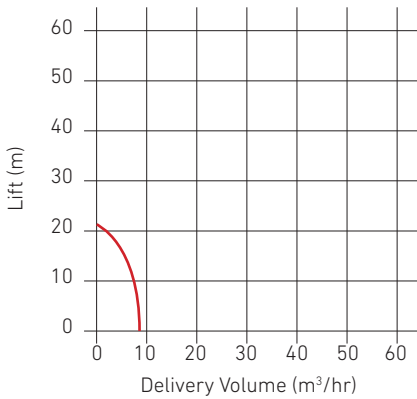

**LC25ZB21-1.7Q5**

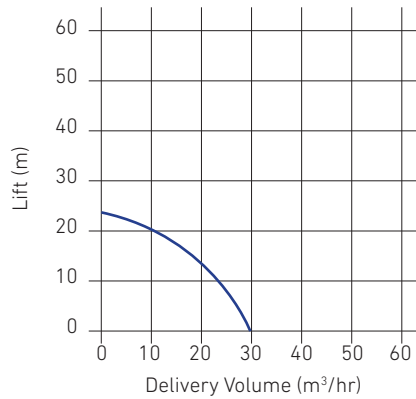

**LC50ZB30-4.5Q5**

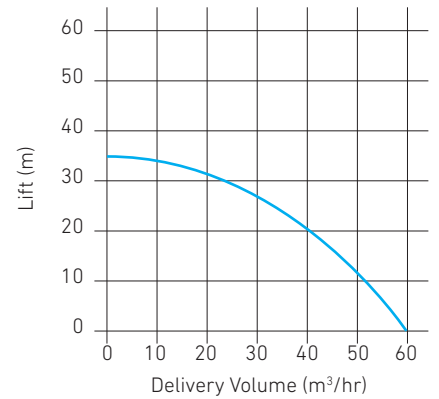

**LC80ZB35-4.5Q5**



**LC50ZB60-4.5Q5**

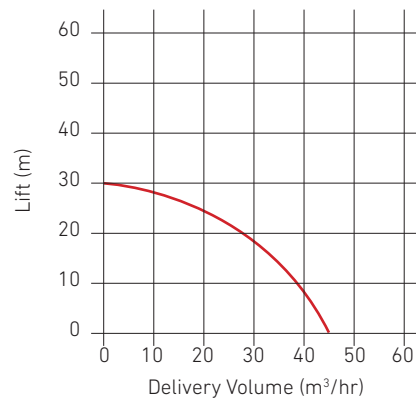

**LC80WB30-4.5Q5**



	LC25ZB21-1.7Q5 1" GENERAL PUMP	LC50ZB30-4.5Q5 2" GENERAL PUMP	LC80ZB35-4.5Q5 3" GENERAL PUMP	LC50ZB60-4.5Q5 2" HIGH LIFT PUMP	LC80WB30-4.5Q5 3" SEMI TRASH PUMP
<b>Pump</b>					
Dia. of Discharge Port (mm)	25	50	80	50	80
Dia. of Suction Port (mm)	25	50	80	50	80
Lift (m)	21	23	35	60	30
Delivery Volume (litres/h)	8,000	30,000	60,000	30,000	45,000
Suction (m)	6				
<b>Engine</b>					
Engine Model	LC152F	G160F	G200F		
Displacement (cc)	97	163	196		
Net Power (hp)	1.6	4.8	5.5		
Rated Speed (rpm)	3600				
Dimensions (mm)	380 x 300 x 370	550 x 430 x 390	550 x 430 x 470	520 x 415 x 460	590 x 480 x 440
Net Weight (kg)	13	23	28	30.5	39



## LC152

Output : 2.1hp / 1.6kW

## H135 - G420

Output : 3.5hp / 2.6kW - 9hp / 12kW

## LC2V80FD

Output : 24.1hp / 18kW

## LC2V90FD

Output : 32hp / 24kW

# Horizontal Engines

## LC-Series/G-Series/V-Twin

### GENERAL PURPOSE ENGINES

Suitable in a wide range of equipment such as gardening, engineering, agriculture, livestock, fishery.

Can be used to repower machinery including generators, snow blowers, water pumps, tillers, pressure washers, road cutters, rammers, shredders.

### LC-SERIES FEATURES

- Large capacity muffler design ensures a lower noise level
- Easy starting. Starts with 3 attempts
- Low oil alert function. Auto-stop when oil is low
- Optimized combustion chamber and air vent, to improve the burning efficiency. Lower fuel consumption and exhaust emission

### G-SERIES FEATURES

- Easy starting. Starts with 3 attempts
- Low oil alert function. Auto-stop when oil is low
- Patented exterior design
- Patented combustion purification technology, very low exhaust emissions

- New combustion chamber design, accurate ignition control and new air vent design improves the power output by 5% compared to the same displaced engines
- Lightweight T-type piston reduces vibration and noise
- Optimized combustion chamber and air vent, to improve the burning efficiency. Lower fuel consumption and exhaust emission

### V-TWIN SERIES FEATURES

- **Low noise and low vibration.** CAE analysis technology is used to optimize component design and reduce vibration and noise
- **Superior reliability.** Internal fuel pump for stability and reliability. Full pressure lubrication extends engine life. Dual-layer cyclone-type air filter with premium filter element prevents dust entering the engine
- **Powerful output.** V-twin cylinder 90° angled OHV design gives a small sized, large displacement, strong power output. Optimized valve timing design and combustion efficiency improves power by 5-10% compared to same displacement engines
- **Low oil consumption.** Optimized air vent cooling system, equipped with oil cooler, decreased oil temperature. Labyrinth type fuel and air separation structure reduces oil consumption



### LC152F-15

- 2.1 / 1.6 @ 3600 r/min
- 87 cc
- L310 x W260 x H305 mm
- 9 kg net weight



### H135

- 3.5 / 2.6 @ 3600 r/min
- 133 cc
- L305 x W341 x H318 mm
- 13 kg net weight



### G200F / F-B5

- 5.5 / 4.1 @ 3600 r/min
- 196 cc
- L376 x W312 x H335 mm
- 16 kg net weight



### G270F

- 8.0 / 6.0 @ 3600 r/min
- 270 cc
- L430 x W380 x H410 mm
- 25 kg net weight



### G390F

- 11 / 8.2 @ 3600 r/min
- 389 cc
- L450 x W405 x H443 mm
- 31 kg net weight



### G420F

- 12 / 9 @ 3600 r/min
- 420 cc
- L450 x W405 x H443 mm
- 31 kg net weight



### LC2V80FD-1

- 24.1 / 18 @ 3600 r/min
- 764 cc
- L507 x W552 x H500 mm
- 50.5 kg net weight



### LC2V90FD-1

- 32 / 24 @ 3600 r/min
- 999 cc
- L555 x W567 x H685 mm
- 60 kg net weight

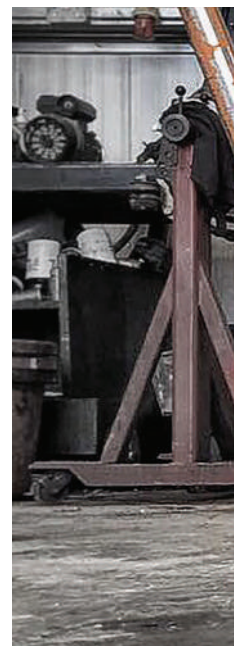

# Horizontal Engines

## Specifications

Engine Model	LC152F-15	H135 (G120)	G200F-B5
Engine Type	Single cylinder, 4-stroke, OHV, forced air cooling		
Net Power (hp / kW)	2.1 / 1.6 @ 3600 r/min	3.5 / 2.6 @ 3600 r/min	5.5 / 4.1 @ 3600 r/min
Gross Power (hp / kW)	2.8 / 2.1 @ 3600 r/min	4.3 / 3.2 @ 3600 r/min	6.5 / 4.85 @ 3600 r/min
Net Torque (Nm)	4.5 @ 3000 r/min	7.3 @ 2800 r/min	12.4 @ 2500 r/min
Bore x Stroke (mm)	54 x 38	62 x 44	68 x 54
Displacement (cc)	87	133	196
Compression Ratio	8.0 : 1		8.5 : 1
Oil Capacity (L)	0.45		0.6
Fuel Consumption (g/kw h)	≤ 450	-	≤ 395
Oil Consumption (g/kw h)		≤ 6.8	
Idle Speed	1700 ± 150	-	1450 ± 150
Starting System	Recoil		Recoil / Electric start opt
Noise (≤ 7m)	70dBA	-	70dBA
Dimensions (L x W x H mm)	310 x 260 x 305	305 x 341 x 318	376 x 312 x 335
Net Weight (kg)	9	13	16
Shaft Options	All shaft options on page 25		



Engine Model	G200F	G270F	G390F
Engine Type	Single cylinder, 4-stroke, OHV, forced air cooling		
Net Power (hp / kW)	5.5 / 4.1 @ 3600 r/min	8.0 / 6.0 @ 3600 r/min	11 / 8.2 @ 3600 r/min
Gross Power (hp / kW)	6.5 / 4.85 @ 3600 r/min	9.0 / 6.7 @ 3600 r/min	13 / 9.7 @ 3600 r/min
Net Torque (Nm)	12.4 @ 2500 r/min	16.3 @ 2500 r/min	25.1 @ 2500 r/min
Bore x Stroke (mm)	68 x 54	77 x 58	88 x 64
Displacement (cc)	196	270	389
Compression Ratio	8.5 : 1	8.1 : 1	8 : 1
Oil Capacity (L)	0.6	0.95	1.1
Fuel Consumption (g/kw h)	≤ 395	≤ 374	
Oil Consumption (g/kw h)	≤ 6.8		
Idle Speed	1450 ± 150		
Starting System	Recoil / Electric start optional		
Noise (≤ 7m)	70dBA		
Dimensions (L x W x H mm)	376 x 312 x 335	430 x 380 x 410	450 x 405 x 443
Net Weight (kg)	16	25	31
Shaft Options	All shaft options on page 25		

Engine Model	G420F	LC2V80FD-1	LC2V90FD-1
Engine Type	Single cylinder, 4-stroke, OHV, forced air cooling	V-Twin, 4-stroke, OHV, forced air cooling	
Net Power (hp / kW)	12 / 9 @ 3600 r/min	24.1 / 19 @ 3600 r/min	32 / 22 @ 3600 r/min
Gross Power (hp / kW)	15 / 11.2 @ 3600 r/min	-	-
Net Torque (Nm)	26.5 @ 2500 r/min	52 @ 2800 r/min	70 @ 2500 r/min
Bore x Stroke (mm)	90 x 66	80 x 76	90 x 78.5
Displacement (cc)	420	764	999
Compression Ratio	8.3 : 1	8.5 : 1	
Oil Capacity (L)	1.1	1.8	2.5
Fuel Consumption (g/kw h)	≤ 374	≤ 360	-
Oil Consumption (g/kw h)	≤ 6.8	-	-
Idle Speed	1450 ± 150	1500 ± 150	1800 ± 150
Starting System	Recoil / Electric start optional	Electric	
Noise (≤ 7m)	70dBA	-	-
Dimensions (L x W x H mm)	450 x 405 x 443	507 x 552 x 500	555 x 567 x 685
Net Weight (kg)	31	50.5	60
Shaft Options	All shaft options on page 25		



# Horizontal Engines

## Power Curves

LC152F-P/F-15/F-M5

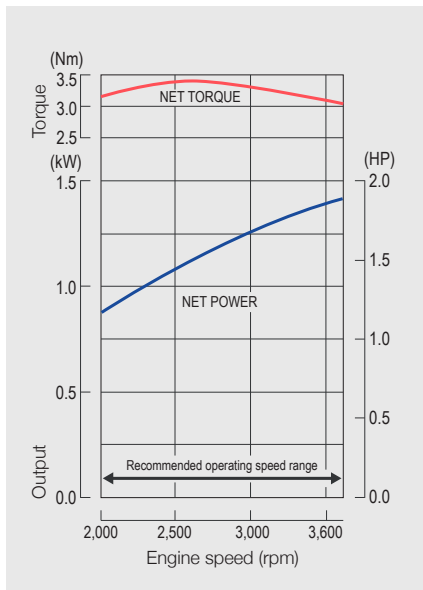

H135F-M5/F-P5

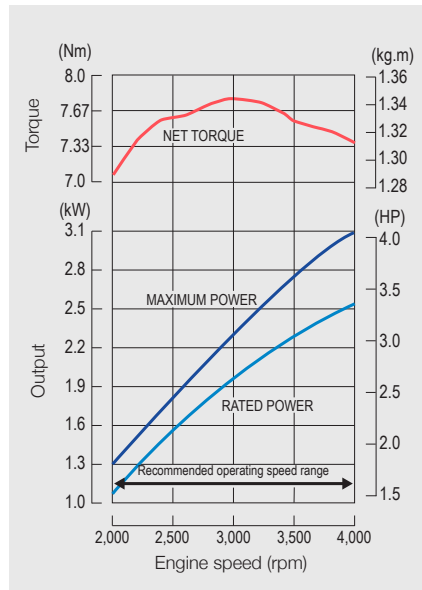

G200F / G200F-B5

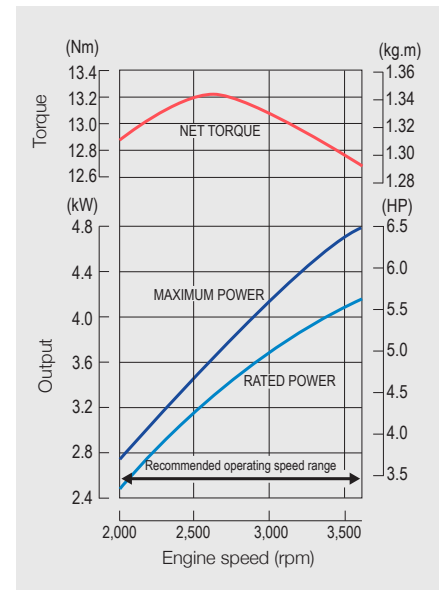



**G200F / G200F-B5**

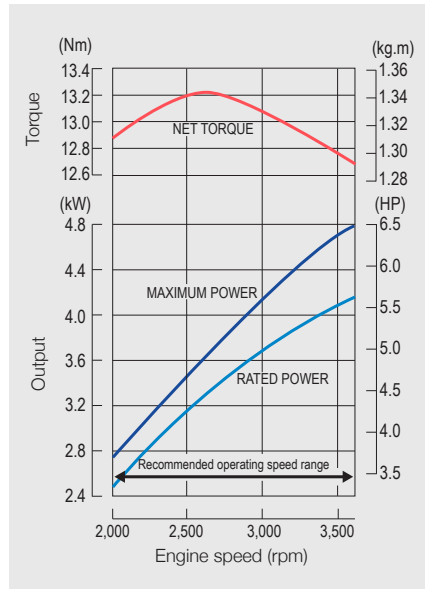

**G270F**

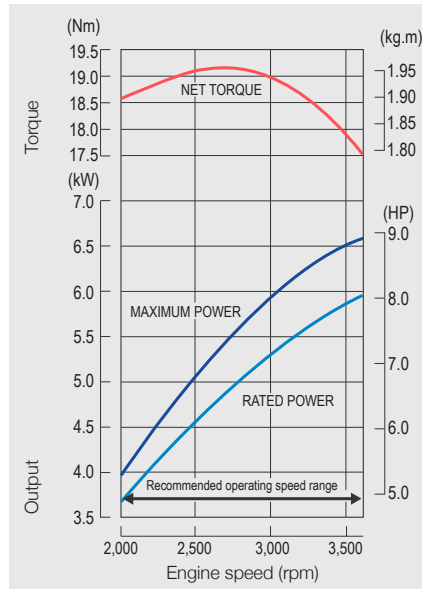

**G390F**

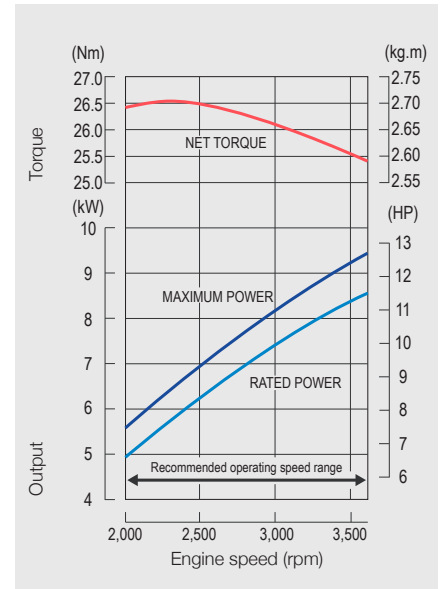

**G420F**

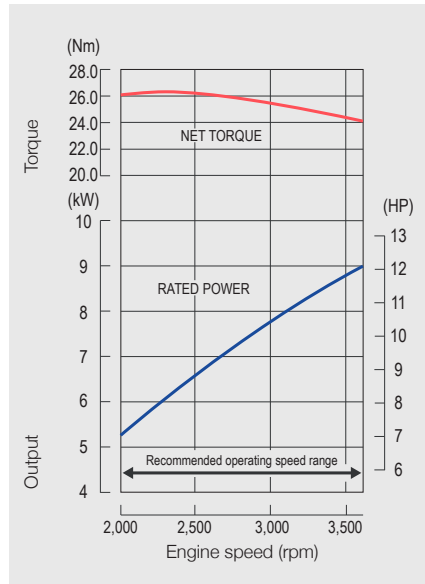

**LC2V80FD-1**

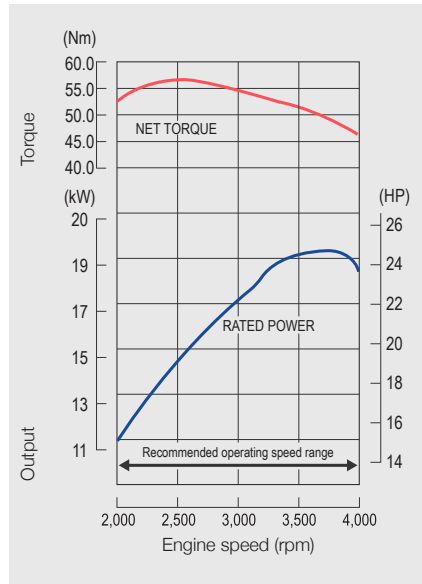

**LC2V90FD-1**

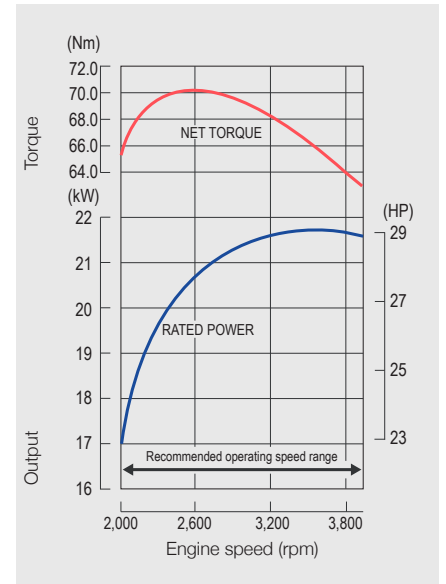



# Horizontal Engines

## Dimensions & Shafts

LC152F-P/F-15/F-M5

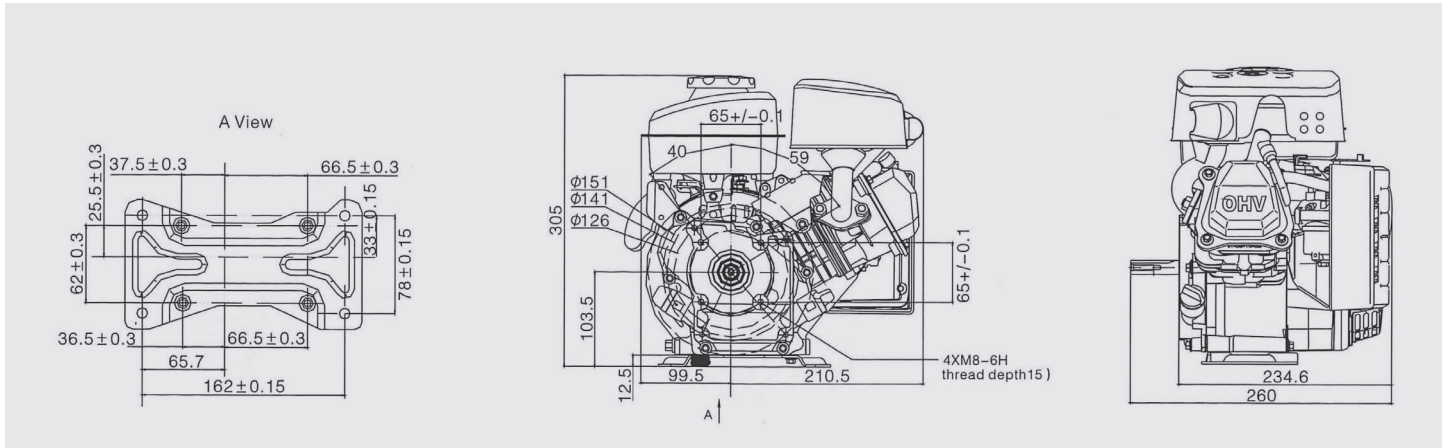

H135F-M5/F-P5 (G120)

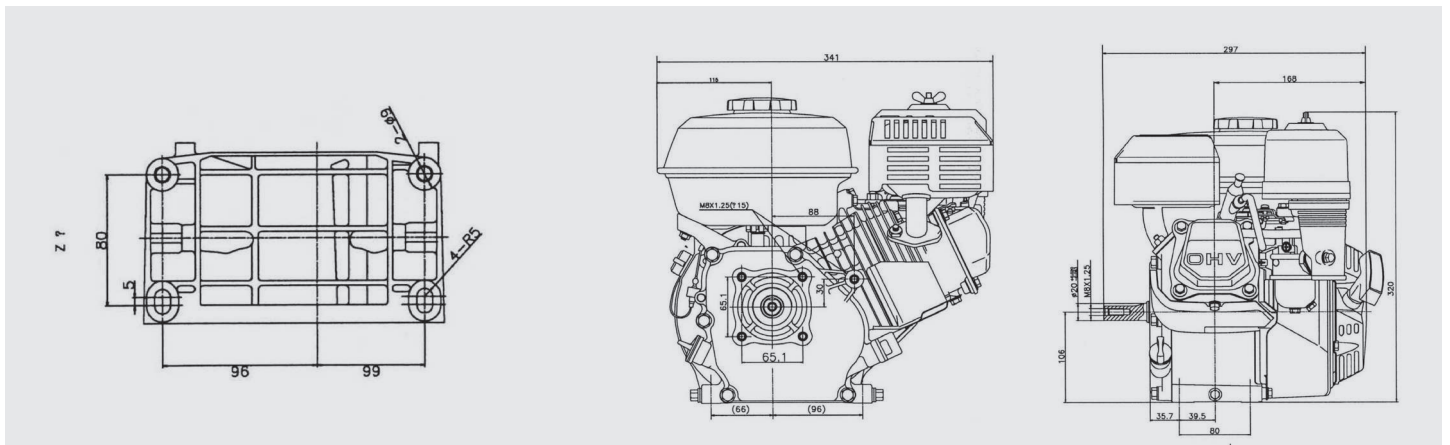

### G200F-B5

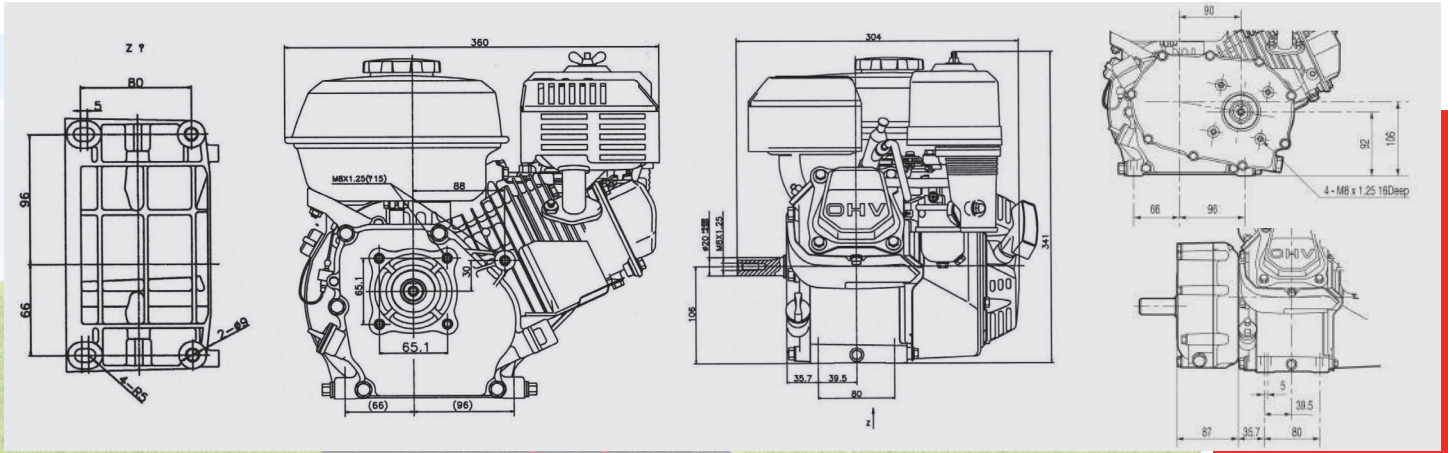

### G200F

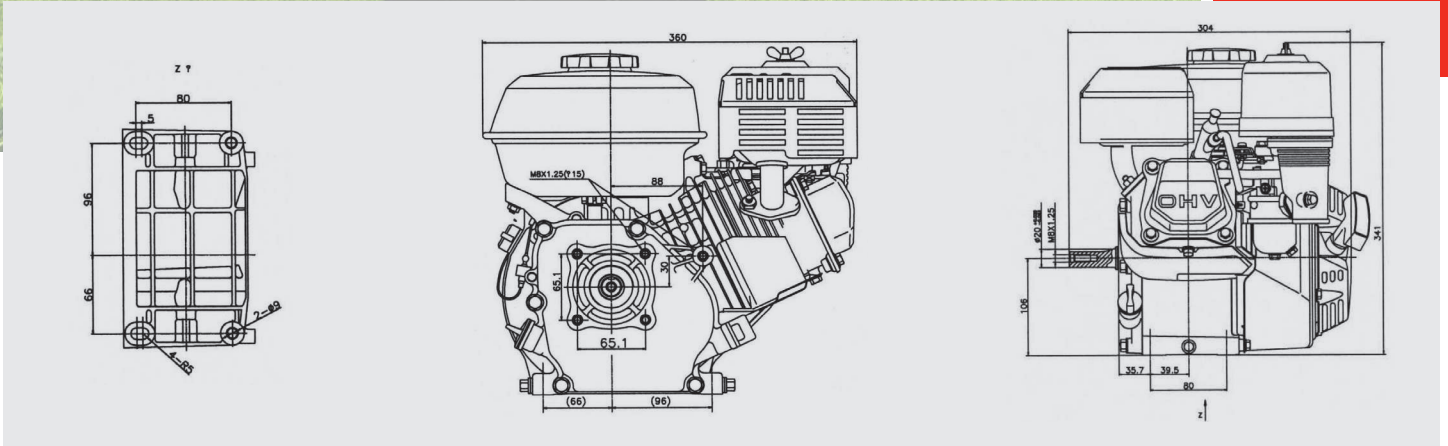

### G270F

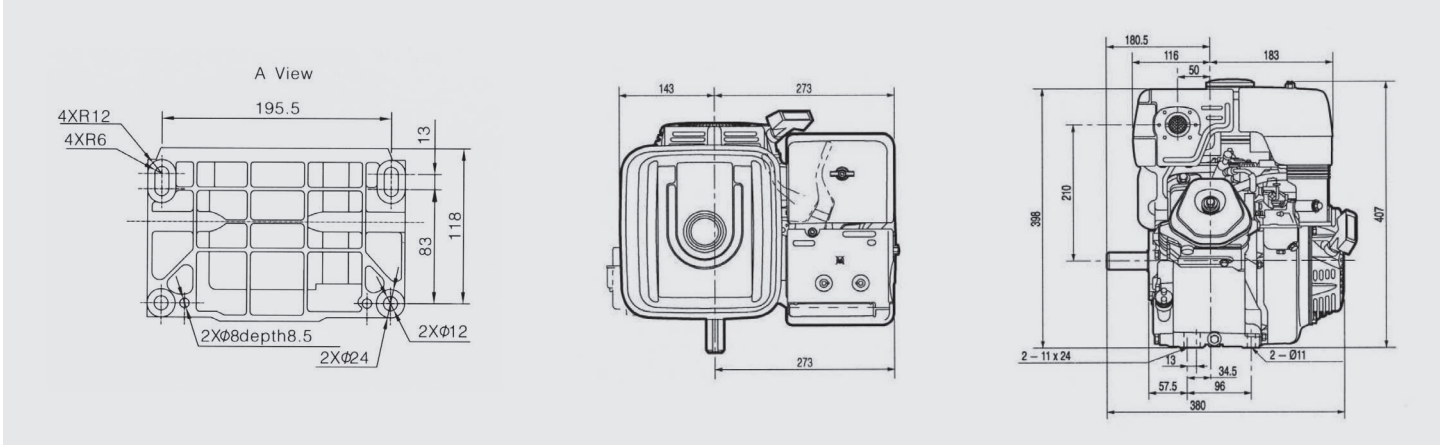

### G390F

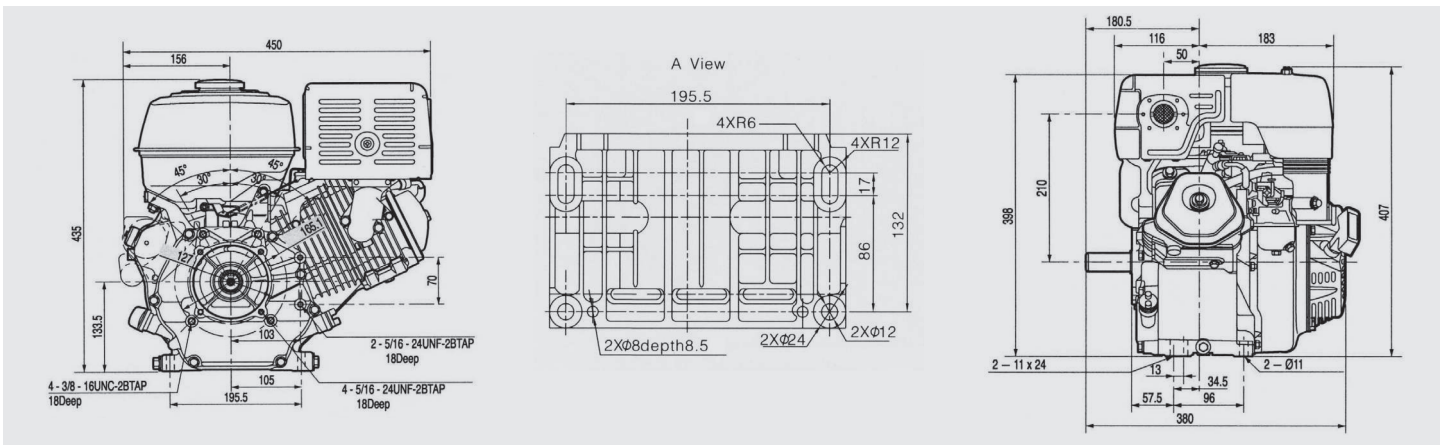



### H135 M-SHAFT

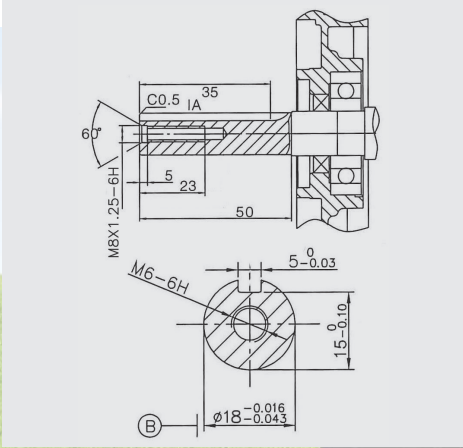

### H135 P-SHAFT

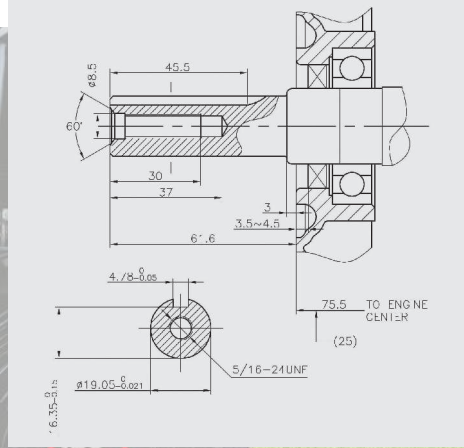

### G200 G-SHAFT

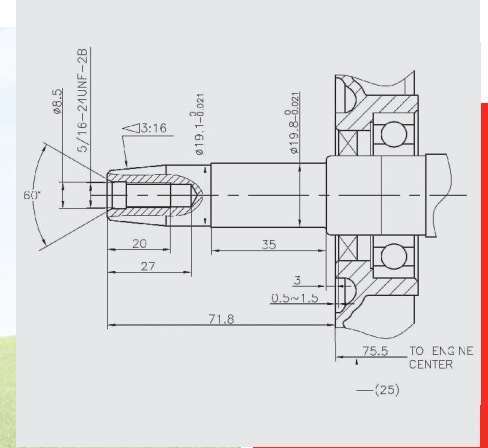

### G200 M-SHAFT



### G200 P-SHAFT

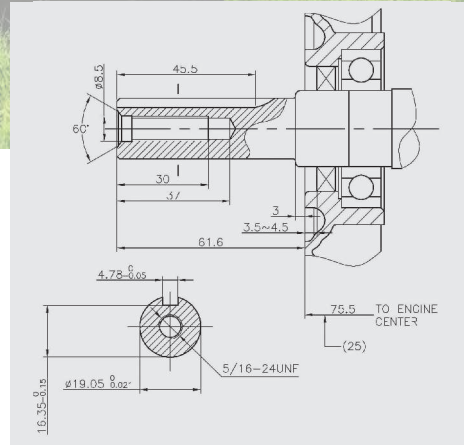

### G270 M-SHAFT

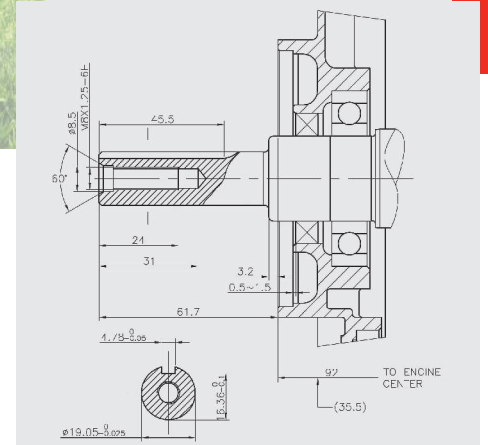

### G270 P-SHAFT

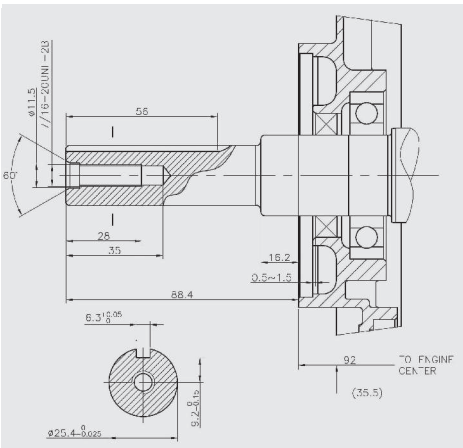

### G390 / G420 G-SHAFT

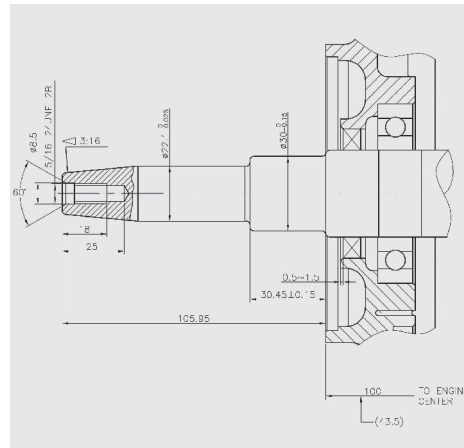

### G390 / G420 P-SHAFT

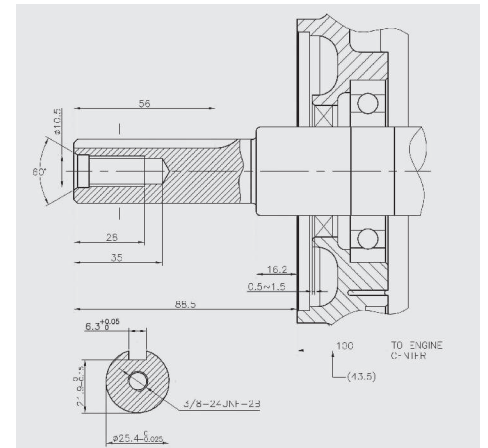

### LC2V80FD-1 P-SHAFT

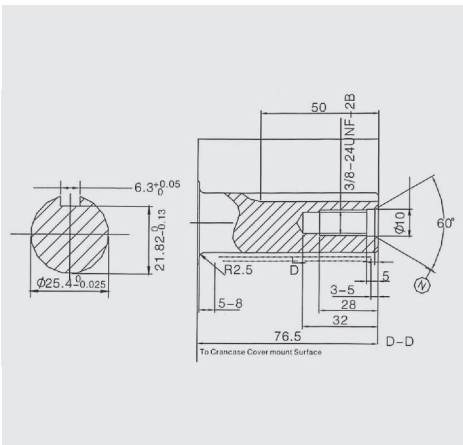

### LC2V90FD-1 G-SHAFT

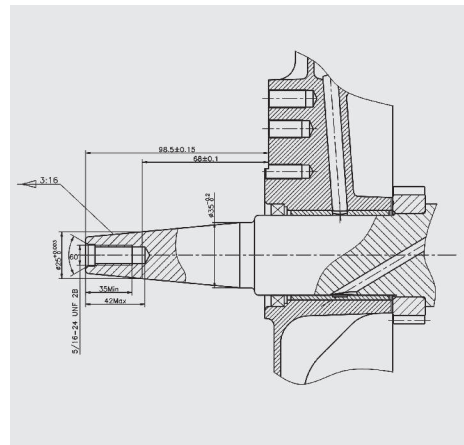

### LC2V90FD-1 P-SHAFT

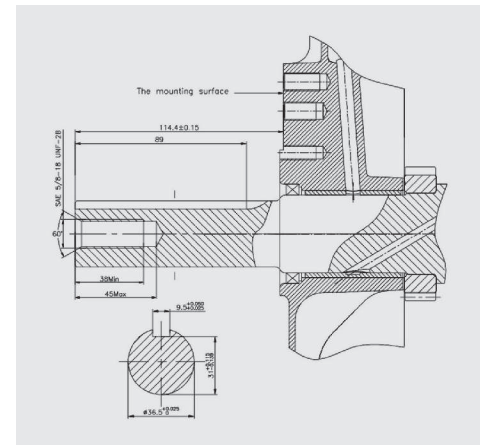



# Vertical Engines

## Single Cylinder/V-Twin

**LC1P70F-3**

Output : 5.3hp / 5kW

**LC1P92F-15**

Output : 14hp / 9.5kW

**LC2P80F5**

Output : 19.3hp / 14.4kW

### PROFESSIONAL COMPLETE POWER PRODUCT

Loncin is the only manufacturer that is able to provide full range of engines with horizontal shaft and vertical shaft in China, of which the vertical shaft power products cover 140-803cc.. It provides global customers with comprehensive general power solutions and serves as a supplier of professional low-carbon complete power product and service.

### FIRST CHOICE OF GENERAL PURPOSE ENGINE

Loncin has provided world-renowned brands-GGP, E-Mark, Toro and Rover with millions of excellent power products continuously. They are widely used for hand-push lawn mower, lawn vehicle, generator, high voltage cleaning machine, mini-tiller and other machinery.

### LARGE VERTICAL SHAFT SERIES

Optimized balance system enables more stable operation. Polar oil filter system lubricates engine sufficiently and extends the engine service life. Cast iron cylinder sleeves, metal cams, forged crankshafts make the engine more durable.

### AFTER-SALE QUALITY ASSURANCE

The products are easy to be started, powerful, durable and reliable, meeting environmental standards and provided with comprehensive after-sales service.

### SMALL VERTICAL SHAFT SERIES

Loncin is excellent supplier of precise spare parts. This series product is featured with easy to be started, simple operation, strong power and compliance with environmental standards.

### DOUBLE-CYLINDER VERTICAL SHAFT

The balanced design of dynamic crankshaft reduces vibration. Press-type machine oil pump can improve the engine lubrication to extend engine service life; fan with high flow can reduce the engine temperature. The cobalt alloy surfacing technology is used for hard alloy intake and exhaust valves to make the engine more wear-resisting.

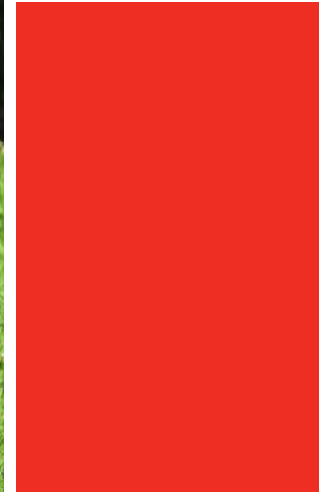

### LC1P70F-3

- 5.3 / 4.0 @ 2500 r/min
- 196 cc
- L384 x W341 x H250 mm
- 12.8 kg net weight



### LC1P92F-15

- 14 / 9.5 @ 2600 r/min
- 452 cc
- L432 x W388 x H300 mm
- 31 kg net weight



### LC2P80F5

- 19.3 / 14.4 @ 3600 r/min
- 764 cc
- L466 x W480 x H356 mm
- 42 kg net weight

Engine Model	LC1P70F-3	LC1P92F-15	LC2P80F5
Engine Type	Single cylinder, 4-stroke, OHV, forced air cooling		V-Twin, 4-stroke, OHV, forced air cooling
Net Power (hp / kW)	5.3 / 4.0 @ 2500 r/min	14 / 9.5 @ 2600 r/min	19.3 / 14.4 @ 2400 r/min
Gross Power (hp / kW)	? / ? @ 2500 r/min	? / ? @ 63600 r/min	? / ? @ 2400 r/min
Net Torque (Nm)	12 @ 2500 r/min	27 @ 2800 r/min	52 @ 2400 r/min
Bore x Stroke (mm)	70 x 50.84	92 x 68	80 x 76
Displacement (cc)	196	452	764
Oil Capacity (L)	0.5	1.2	2.4
Starting System	Recoil / Electric	Electric	Electric
Dimensions (L x W x H mm)	384 x 341 x 258	432 x 388 x 300	466 x 480 x 356
Net Weight (kg)	12.8	31	42
Shaft Options	All shaft options on page 29		



# Vertical Engines

## Curves / Dimensions / Shafts

LC1P70F-3

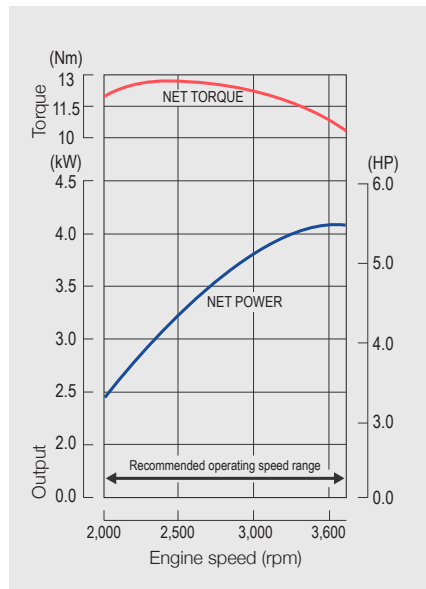

LC1P92F-15



LC2P80F5

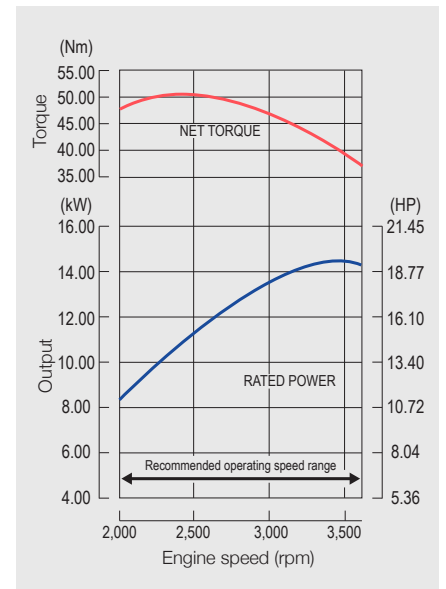

### LC1P70F-3

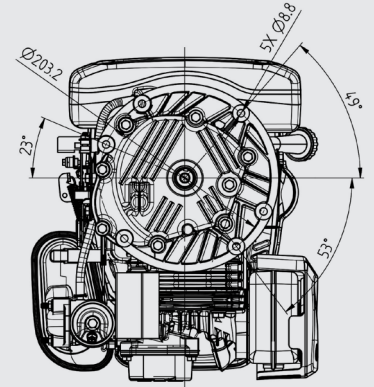
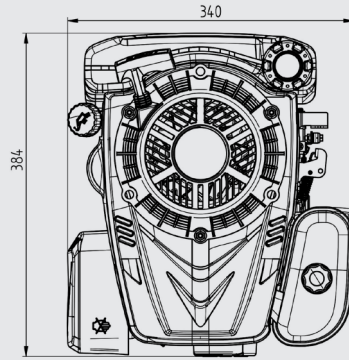
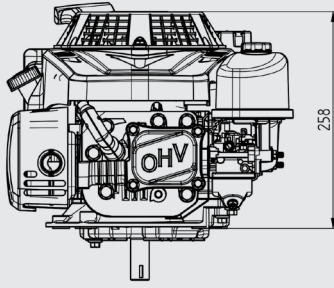

### LC1P92F-15

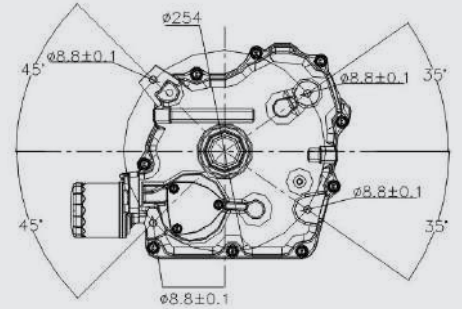
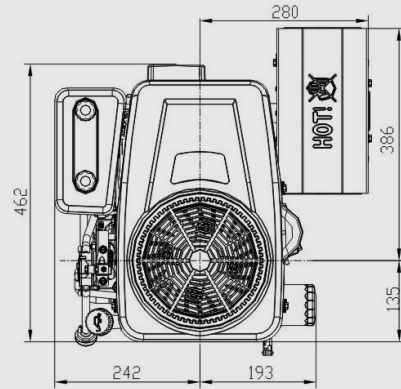
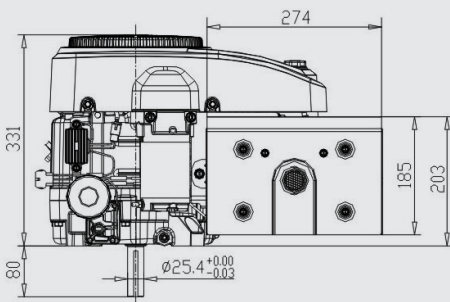

### LC2P80F5

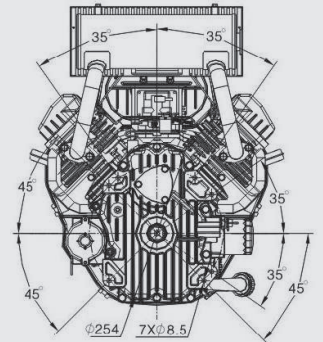
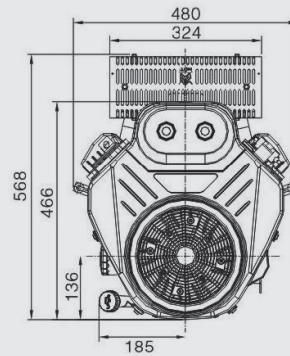
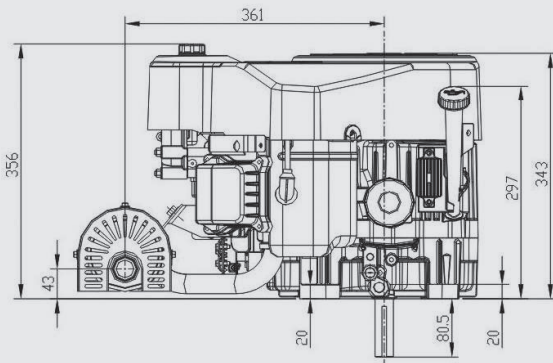

### LC1P70F-3

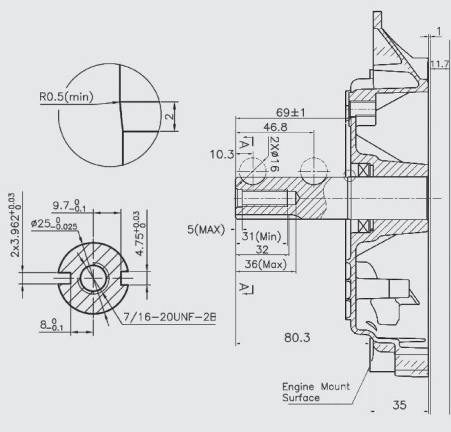

### LC1P92F-15

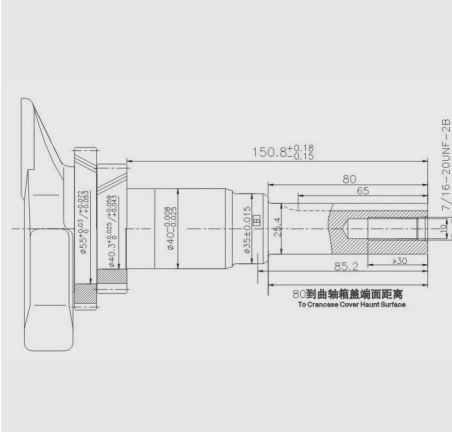

### LC2P80F5

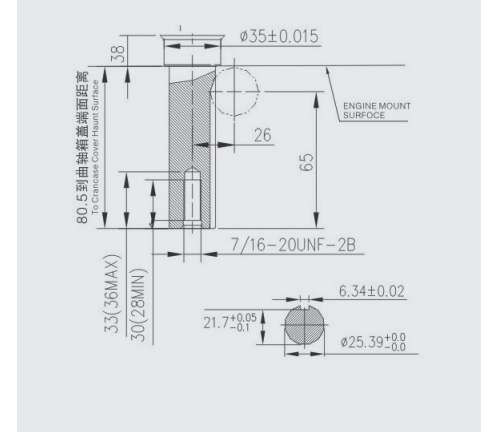



# Loncin Repower & 2 Year Warranty

THE LONCIN ENGINE SERIES OFFERS A COST EFFECTIVE OPTION FOR THE REPOWER MARKET

- Durable
- High performance
- Electric start optional
- Low noise
- Fuel efficient
- Standard engine drive shafts
- Standard mounting points

## CONSTRUCTION



## PLANT AND TOOL



## GROUND CARE/UTILITY



## LEISURE





# International Cooperation

MOTORCYCLE COOPERATION WITH BMW SINCE 2005 OFFERS LONCIN A VERY ADVANCED QUALITY CONTROL SYSTEM. LONCIN ALSO HAVE ODM COOPERATION WITH WELL-KNOWN INTERNATIONAL COMPANIES.





# POWERING THE FUTURE



TWO YEAR WARRANTY ON ALL LONCIN PRODUCTS



**The Power  
Behind The Brands**

Specifications and/or prices are subject to change without notice.  
Every effort is made to produce sales literature and price lists that are accurate and current.

**Loncin - Supported by Barrus**

E. P. Barrus Ltd., Glen Way, Launton Road, Bicester, Oxfordshire, OX26 4UR  
Tel: 01869 363606 Email: [loncin@barrus.co.uk](mailto:loncin@barrus.co.uk) [www.barrus.co.uk](http://www.barrus.co.uk)

